

8961726 TEXAS INSTR (OPT0)

62C 36982 D

**TIP660, TIP661, TIP662**  
**N-P-N DARLINGTON-CONNECTED**  
**SILICON POWER TRANSISTORS**

REVISED OCTOBER 1984

T-33-29

- 80 W at 100° C Case Temperature
- 10 A Rated Continuous Collector Current
- MAX VCE(sat) of 2.8 V at 6.5 A
- High-Voltage, High Forward and Reverse Energy
- Designed For Automotive Ignition Applications
- Characterized For Operation In Ignition and Switching Regulator Applications

device schematic

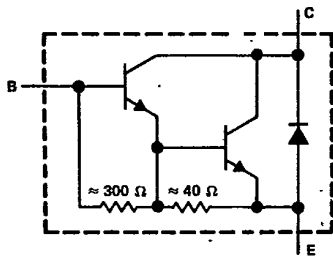

TO-3 PACKAGE

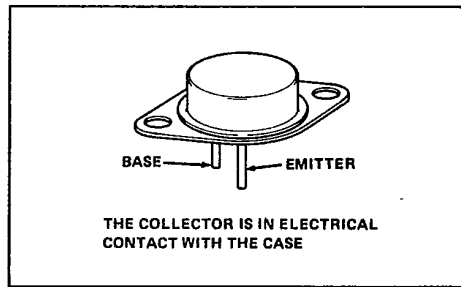

absolute maximum ratings at 25° C case temperature (unless otherwise noted)

	TIP660	TIP661	TIP662
Collector-base voltage	320 V	350 V	380 V
Collector-emitter voltage ( $I_B = 0$ )	320 V	350 V	380 V
Emitter-base voltage	5 V		
Continuous collector current	10 V		
Peak collector current (see Note 1)	16 A		
Commutating diode current (see Note 2)	10 A		
Continuous base current	1 A		
Continuous device dissipation at (or below) 100° C case temperature (see Note 3)	80 W		
Continuous device dissipation at (or below) 25° C free-air temperature (see Note 4)	5.5 W		
Safe operating area at (or below) 100° C case temperature	See Figure 9		
Operating collector junction and storage temperature range	- 65° C to 200° C		
Lead temperature 3,2 mm (0.125 inch) from case for 10 seconds	300° C		

- NOTES: 1. This value applies for  $t_W \leq 10$  ms, duty cycle  $\leq 10$  %.
2. This applies to the total collector terminal current when the collector is at negative potential with respect to the emitter.
3. Derate linearly to 200° C case temperature at the rate of 0.8 W/C or refer to Dissipation Derating Curve, Figure 10.
4. Derate linearly to 200° C free-air temperature at the rate of 31.4 mW/C or refer to Dissipation Derating Curve, Figure 11.

5  
TIP Devices

8961726 TEXAS INSTR (OPTO)

62C 36983 D

TIP660, TIP661, TIP662  
N-P-N DARLINGTON-CONNECTED  
SILICON POWER TRANSISTORS

T-33-29

electrical characteristics at 25°C case temperature

PARAMETER	TEST CONDITIONS	TIP660			TIP661			TIP662			UNIT
		MIN	TYP	MAX	MIN	TYP	MAX	MIN	TYP	MAX	
I <sub>CEO</sub>	V <sub>CE</sub> = 320 V, I <sub>B</sub> = 0			1			1				mA
	V <sub>CE</sub> = 350 V, I <sub>B</sub> = 0										
	V <sub>CE</sub> = 380 V, I <sub>B</sub> = 0								1		
I <sub>EBO</sub>	V <sub>EB</sub> = 5 V, I <sub>C</sub> = 0			100			100			100	mA
h <sub>FE</sub>	V <sub>CE</sub> = 2.2 V, I <sub>C</sub> = 4 A, See Notes 5 and 6			200			200			200	
V <sub>BE</sub>	I <sub>B</sub> = 0.1 A, I <sub>C</sub> = 6.5 A, See Notes 5 and 6			2.2			2.2			2.2	V
V <sub>CE(sat)</sub>	I <sub>B</sub> = 0.1 A, I <sub>C</sub> = 6.5 A, See Notes 5 and 6			2.8			2.8			2.8	V
	I <sub>B</sub> = 1 A, I <sub>C</sub> = 10 A, See Notes 5 and 6			2.9			2.9			2.9	
V <sub>F</sub>	I <sub>F</sub> = 10 A, See Notes 5 and 6			3.5			3.5			3.5	V

NOTES: 5. These parameters must be measured using pulse techniques, t<sub>w</sub> = 300 μs, duty cycle ≤ 2 %.  
6. These parameters are measured with voltage-sensing contacts separate from the current-carrying contacts located within 3,2 mm (0.125 inch) from the device body.

thermal characteristics

PARAMETER	MIN	TYP	MAX	UNIT
R <sub>θJC</sub>			1.25	°C/W
R <sub>θJA</sub>			31.8	
R <sub>θCHS</sub> See Note 7			0.4	

NOTE 7: This parameter is measured using a 0,08 mm mica insulator with Dow-Corning 11 compound on both sides of the insulator, a 6-32 mounting screw with bushing, and a mounting torque of 0.9 Newton meter.

resistive-load switching characteristics at 25°C case temperature

PARAMETER	TEST CONDITIONS†	MIN	TYP	MAX	UNIT
t <sub>d</sub>	I <sub>C</sub> = 6.5 A, I <sub>B1</sub> = 100 mA, I <sub>B2</sub> = -100 mA, V <sub>BE(off)</sub> = -5 V, R <sub>L</sub> = 5 Ω, See Figure 1			0.04	μs
t <sub>r</sub>		1.5			
t <sub>s</sub>		2.2			
t <sub>f</sub>		2.6			

† Voltage and current values shown are nominal; exact values vary slightly with transistor parameters.

functional tests at 25°C free-air temperature

TEST	CONDITIONS	LEVEL
Power (V <sub>CE</sub> • I <sub>C</sub> )	V <sub>CE</sub> = 40 V, I <sub>C</sub> = 2 A, t <sub>test</sub> = 1 s	80 W
Reverse Pulse Energy $\left(\frac{I_C^2 L}{2}\right)$	I <sub>CM</sub> = 6 A, L = 100 mH, f = 10 Hz, t <sub>test</sub> = 0.5 s, See Figure 2	1.8 mJ
Forward Pulse Energy $\left(\frac{I_C^2 L}{2}\right)$	I <sub>CM</sub> = 7 A, L = 5 mH, V <sub>clamp</sub> = V <sub>CEO</sub> max rating, f = 60 Hz, t <sub>test</sub> = 0.5 s, See Figure 3	122.5 mJ

TIP Devices

8961726 TEXAS INSTR (OPTO)

62C 36984 D

TIP660, TIP661, TIP662  
N-P-N DARLINGTON-CONNECTED  
SILICON POWER TRANSISTORS

PARAMETER MEASUREMENT INFORMATION

T-33-29

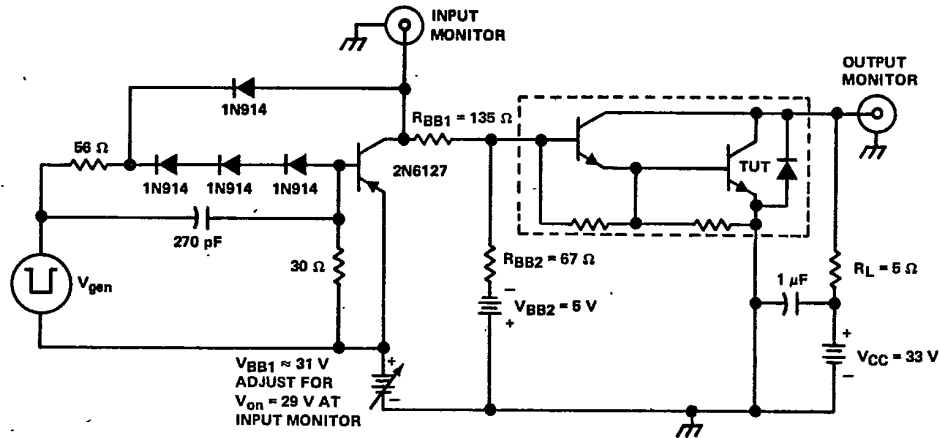

TEST CIRCUIT

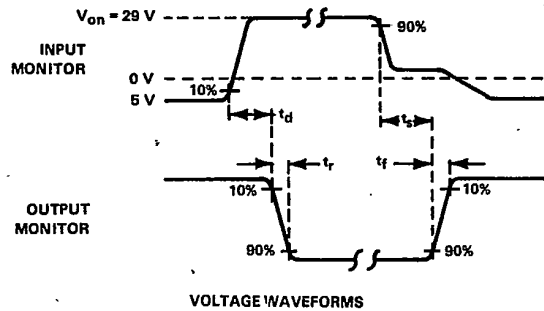

VOLTAGE WAVEFORMS

- NOTES:
- A.  $V_{gen}$  is a -30-V pulse into a 50  $\Omega$  termination.
  - B. The  $V_{gen}$  waveform is supplied by a generator with the following characteristics:  $t_r < 15$  ns,  $t_f < 15$  ns,  $Z_{out} = 50$   $\Omega$ ,  $t_w = 20$   $\mu$ s, duty cycle  $< 2\%$ .
  - C. Waveforms are monitored on an oscilloscope with the following characteristics:  $t_r < 15$  ns,  $R_{in} \geq 10$  M $\Omega$ ,  $C_{in} < 11.5$  pF.
  - D. Resistors must be noninductive types.
  - E. The d-c power supplies may require additional bypassing in order to minimize ringing.

FIGURE 1. RESISTIVE-LOAD SWITCHING

5  
TIP Devices

8961726 TEXAS INSTR (OPTO)

62C 36985 D

TIP660, TIP661, TIP662  
N-P-N DARLINGTON-CONNECTED  
SILICON POWER TRANSISTORS

T-33-29

FUNCTIONAL TEST INFORMATION

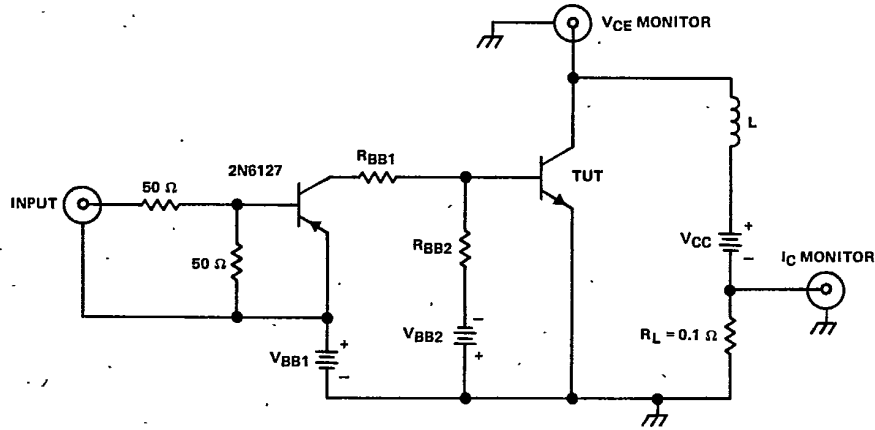

TEST CIRCUIT

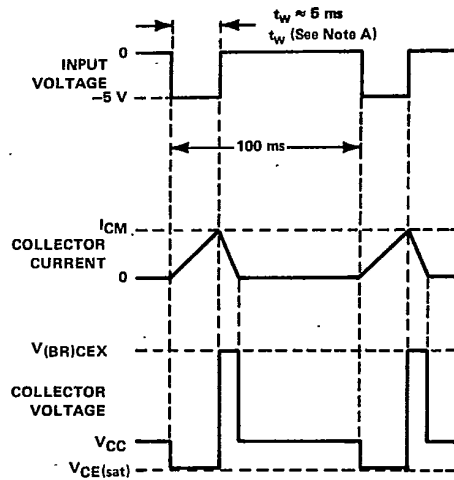

VOLTAGE AND CURRENT WAVEFORMS

NOTE A: Input pulse duration is increased until the peak collector current reaches the specified value of  $I_{CM}$ .

FIGURE 2. REVERSE PULSE ENERGY TEST

5  
TIP Devices

8961726 TEXAS INSTR (OPTO)

62C 36986 D

TIP660, TIP661, TIP662  
N-P-N DARLINGTON-CONNECTED  
SILICON POWER TRANSISTORS

FUNCTIONAL TEST INFORMATION

T-33-29

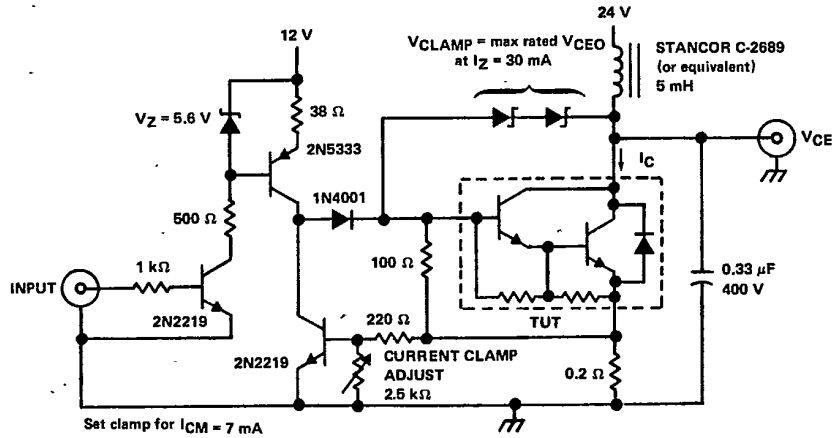

TEST CIRCUIT

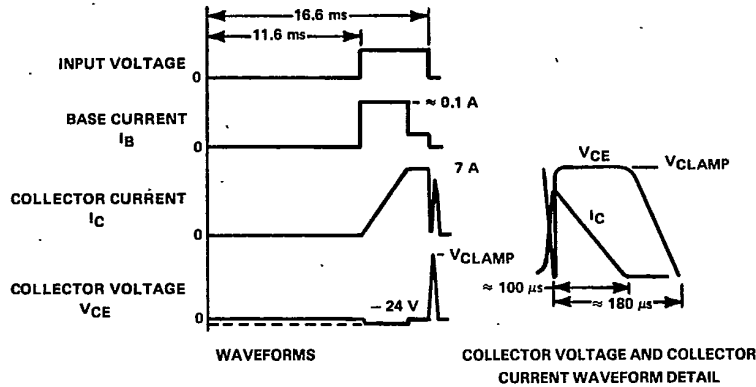

WAVEFORMS

COLLECTOR VOLTAGE AND COLLECTOR CURRENT WAVEFORM DETAIL

- NOTES: A. Base and collector currents are measured using current probes such as Tektronix types P6019, P6020, P6021, P6042 or the equivalent.  
B. Waveforms are monitored on an oscilloscope with the following characteristics:  $t_r \leq 20\text{ ns}$ ,  $R_{in} \geq 10\text{ M}\Omega$ ,  $C_{in} \leq 11.5\text{ pF}$ .

FIGURE 3. FORWARD PULSE ENERGY TEST



TIP Devices

8961726 TEXAS INSTR (OPTO)

62C 36987 D

T-33-29

**TIP660, TIP661, TIP662**  
**N-P-N DARLINGTON-CONNECTED**  
**SILICON POWER TRANSISTORS**

**TYPICAL CHARACTERISTICS**

STATIC FORWARD CURRENT TRANSFER RATIO  
 vs  
 COLLECTOR CURRENT

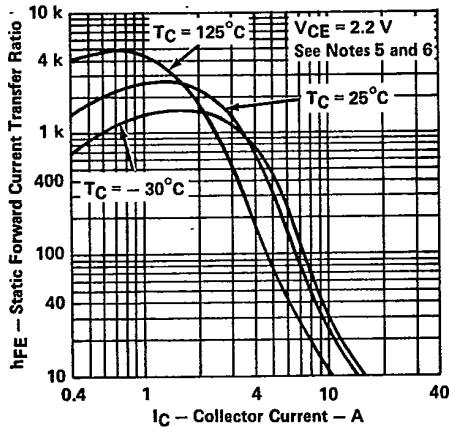

FIGURE 4

BASE-EMITTER VOLTAGE  
 vs  
 COLLECTOR CURRENT

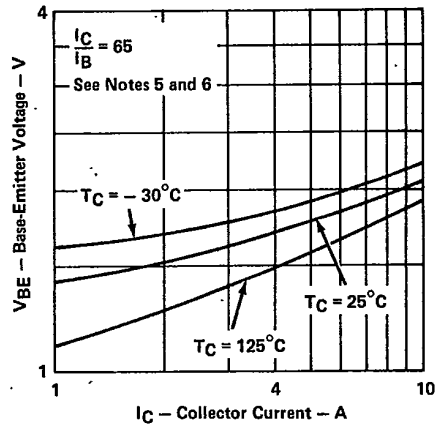

FIGURE 5

BASE-EMITTER VOLTAGE  
 vs  
 COLLECTOR CURRENT

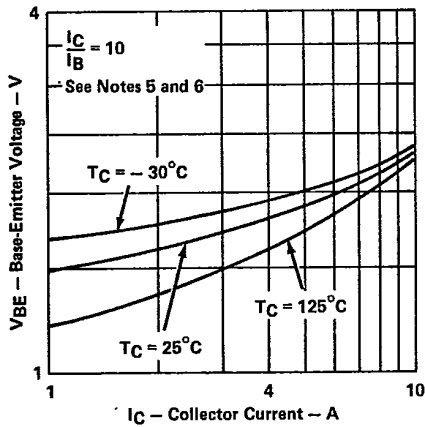

FIGURE 6

COLLECTOR-EMITTER SATURATION VOLTAGE  
 vs  
 COLLECTOR CURRENT

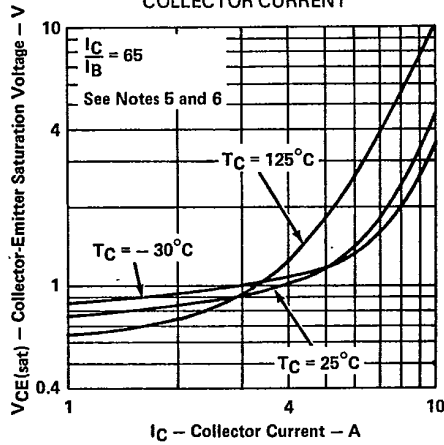

FIGURE 7

- NOTES: 5. These parameters must be measured using pulse techniques,  $t_w = 300 \mu s$ , duty cycle  $\leq 2\%$ .  
 6. These parameters are measured with voltage-sensing contacts separate from the current-carrying contacts located within 3.2 mm (0.125 inch) from the device body.



TIP Devices

8961726 TEXAS INSTR (OPTO)

62C 36988 D

TIP660, TIP661, TIP662  
N-P-N DARLINGTON-CONNECTED  
SILICON POWER TRANSISTORS

TYPICAL CHARACTERISTICS

T-33-29

COLLECTOR-EMITTER SATURATION VOLTAGE  
vs  
COLLECTOR CURRENT

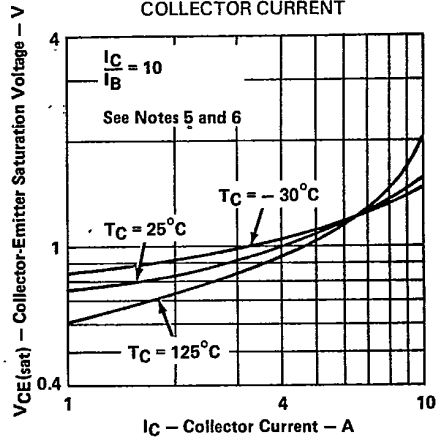

FIGURE 8

- NOTES: 5. These parameters must be measured using pulse techniques,  $t_w = 300 \mu s$ , duty cycle  $\leq 2\%$ .  
6. These parameters are measured with voltage-sensing contacts separate from the current-carrying contacts located within 3,2 mm (0.125 inch) from the device body.

MAXIMUM SAFE OPERATING AREA  
FORWARD-BIAS SAFE OPERATING AREA

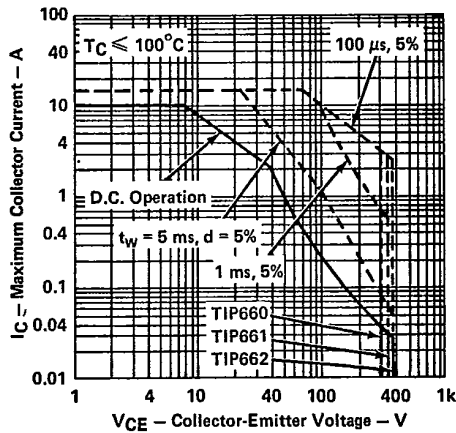

FIGURE 9

5  
TIP Devices

B3

8961726 TEXAS INSTR (OPTO)

62C 36989 D

T-33-29

TIP660, TIP661, TIP662  
N-P-N DARLINGTON-CONNECTED  
SILICON POWER TRANSISTORS

THERMAL INFORMATION

CASE TEMPERATURE  
DISSIPATION DERATING CURVE

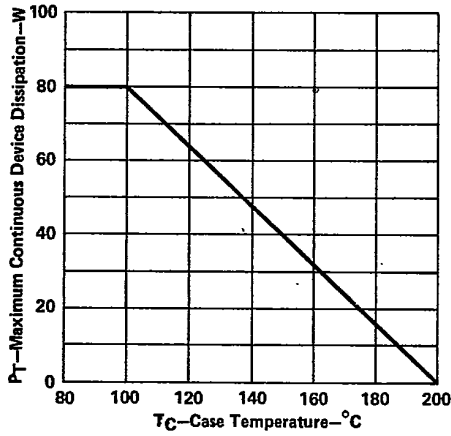

FIGURE 10

FREE-AIR TEMPERATURE  
DISSIPATION DERATING CURVE

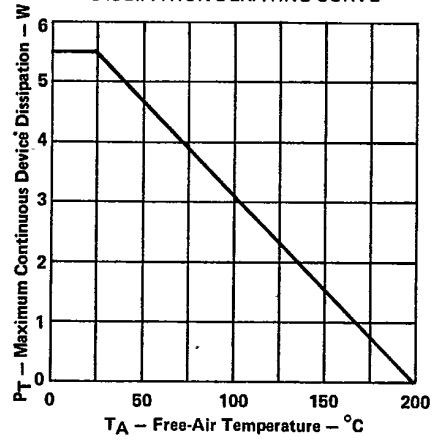

FIGURE 11



TIP Devices