

MC3303/3403/3503 Quad Low Power Operational Amplifiers

Product Specification

Linear Products

DESCRIPTION

The MC3403 is a quad operational amplifier with true differential inputs. The device has electrical characteristics similar to the popular $\mu A741$. However, the MC3403 has several distinct advantages over standard operational amplifier types in single supply applications. The MC3403 can operate at supply voltages as low as 3.0V or as high as 32V. The common-mode input range includes the negative supply, thereby eliminating the necessity for external biasing components in many applications. The output voltage range also includes the negative power supply voltage.

FEATURES

- Short-circuit protected outputs
- Class AB output stage for minimal crossover distortion
- True differential input stage
- Single supply operation: 3.0 to 32V
- Split supply operation: ± 1.5 to $\pm 16V$
- Low input bias currents: 500nA max
- Four amplifiers per package
- Internally compensated

PIN CONFIGURATION

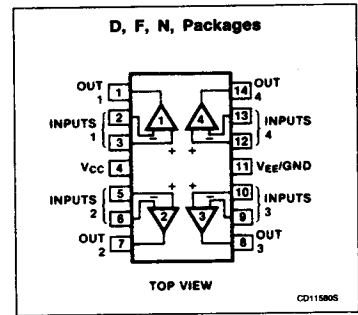

ORDERING INFORMATION

DESCRIPTION	TEMPERATURE RANGE	ORDER CODE
14-Pin Plastic SO	-40°C to +85°C	MC3303D
14-Pin Ceramic DIP	-40°C to +85°C	MC3303F
14-Pin Plastic DIP	-40°C to +85°C	MC3303N
14-Pin Plastic SO	0 to +70°C	MC3403D
14-Pin Ceramic DIP	0 to +70°C	MC3403F
14-Pin Plastic DIP	0 to +70°C	MC3403N
14-Pin Ceramic DIP	-55°C to +125°C	MC3503F

CIRCUIT SCHEMATIC (1/4 Shown)

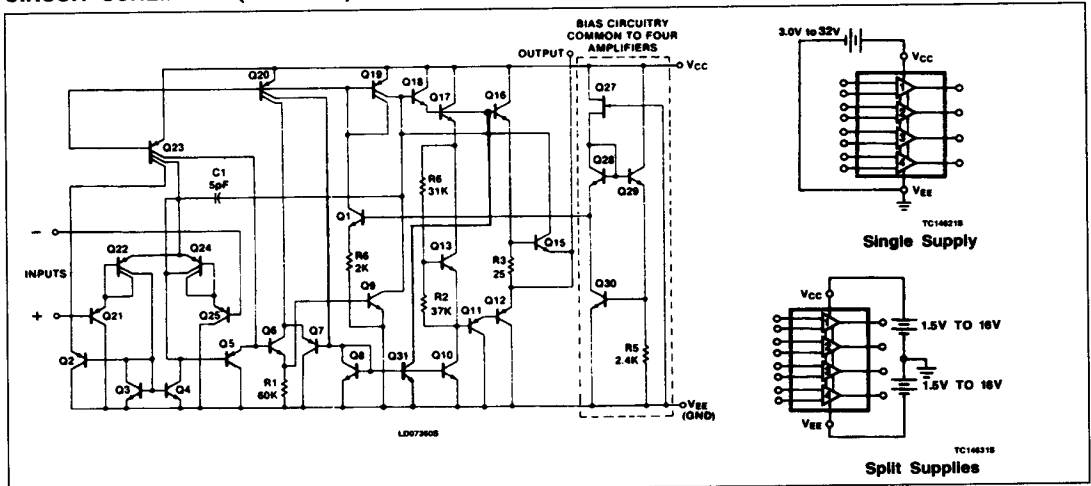

Quad Low Power Operational Amplifiers

MC3303/3403/3503

ABSOLUTE MAXIMUM RATINGS

SYMBOL	PARAMETER	RATING	UNIT
V_{CC} V_{CC} V_{EE}	Power supply voltage ³ Single supply Split supplies	36 +18 -18	V_{DC} V_{DC} V_{DC}
V_{IDR}	Input differential voltage range ¹	± 36	V_{DC}
V_{ICR}	Input common-mode voltage range ^{1, 2}	± 18	V_{DC}
P_D MAX	Maximum power dissipation, $T_A = 25^\circ\text{C}$ (still-air) ⁴ F package D package N package	1.20 1.04 1.45	W W W
T_{STG}	Storage temperature range Ceramic Plastic	-65 to +150 -55 to +125	$^\circ\text{C}$
T_A	Operating ambient temperature range MC3503 MC3403 MC3303	-55 to +125 0 to +70 -40 to +85	$^\circ\text{C}$ $^\circ\text{C}$ $^\circ\text{C}$
T_J	Junction temperature	150	$^\circ\text{C}$

NOTES:

- Split power supplies.
- For supply voltages less than $\pm 15\text{V}$, the absolute maximum input voltage is equal to the supply voltage.
- Device not functional for single supply $> 32\text{V}$ or split supply $> \pm 16\text{V}$.
- Derate above 25°C at the following rates:
F package at $9.5\text{mW}/^\circ\text{C}$
D package at $8.7\text{mW}/^\circ\text{C}$
N package at $11.6\text{mW}/^\circ\text{C}$

DC AND AC ELECTRICAL CHARACTERISTICS $V_{CC} = +15\text{V}$, $V_{EE} = -15\text{V}$ for MC3503, MC3403; $V_{CC} = +14\text{V}$, $V_{EE} = \text{GND}$ for MC3303. $T_A = 25^\circ\text{C}$, unless otherwise noted.

SYMBOL	PARAMETER	TEST CONDITIONS	MC3503			MC3403			MC3303			UNIT
			Min	Typ	Max	Min	Typ	Max	Min	Typ	Max	
V_{IO}	Input offset voltage	$T_A = T_{HIGH}$ to T_{LOW}		2.0	5.0 6.0		2.0	10 12		2.0	8.0 10	mV
I_{IO}	Input offset current	$T_A = T_{HIGH}$ to T_{LOW}		10	50 200		10	50 200		30	75 250	nA
A_{VOL}	Large-signal open-loop voltage gain	$V_O = \pm 10\text{V}$, $V_O = \pm 10\text{V}$ $R_L = 2.0\text{k}\Omega$ $T_A = T_{HIGH}$ to T_{LOW}	50 50 25	200 200 300		20 20 15	200 200		20 20 15	200 200		V/mV
I_{BIAS}	Input bias current	$T_A = T_{HIGH}$ to T_{LOW}		-30 -40	-500 -1200		-30	-500 -800		-30	-500 -1000	nA
Z_O	Output impedance	$f = 20\text{Hz}$		75			75			75		Ω
Z_i	Input impedance	$f = 20\text{Hz}$	0.3	1.0		0.3	1.0		0.3	1.0		M Ω
V_{OR}	Output voltage range	$R_L = 10\text{k}\Omega$ $R_L = 2.0\text{k}\Omega$ $R_L = 2.0\text{k}\Omega$ $T_A = T_{HIGH}$ to T_{LOW}	± 12 ± 10	± 13.5 ± 13		± 12 ± 10 ± 10	± 13.5 ± 13		+12 +10 +10	+12.5 +12		V

Quad Low Power Operational Amplifiers

MC3303/3403/3503

DC AND AC ELECTRICAL CHARACTERISTICS (Continued) $V_{CC} = +15V$, $V_{EE} = -15V$ for MC3503, MC3403;
 $V_{CC} = +14V$, $V_{EE} = GND$ for MC3303. $T_A = 25^\circ C$, unless otherwise noted.

SYMBOL	PARAMETER	TEST CONDITIONS	MC3503			MC3403			MC3303			UNIT
			Min	Typ	Max	Min	Typ	Max	Min	Typ	Max	
V_{ICR}	Input common-mode voltage range		+13 - V_{EE}	+13.5 - V_{EE}		+13 - V_{EE}	+13.5 - V_{EE}		+12 - V_{EE}	+12.5 - V_{EE}		V
CMRR	Common-mode rejection ratio	$R_S \leq 10k\Omega$	70	90		70	90		70	90		dB
I_{CC} , I_{EE}	Power supply current ($V_O = 0$)	$R_L = \infty$ $T_A = T_{HIGH}$ to T_{LOW}		2.5 3.5	4.0 5.0		2.5 3.5	7.0 7.0		2.5 3.5	7.0 7.0	mA mA
$I_{OS\pm}$	Individual output short-circuit current ¹		± 10	± 30	± 45	± 10	± 20	± 45	± 10	± 30	± 45	mA
PSSR+	Positive power supply rejection ratio			30	150		30	150		30	150	$\mu V/V$
PSSR-	Negative power supply rejection ratio			30	150		30	150				$\mu V/V$
$\Delta I_B/\Delta T$	Average temperature coefficient of input bias current	$T_A = T_{HIGH}$ to T_{LOW}		50			50			50		$pA/^\circ C$
$\Delta I_{IO}/\Delta T$	Average temperature coefficient of input offset current	$T_A = T_{HIGH}$ to T_{LOW}		50			50			50		$pA/^\circ C$
$\Delta V_{IO}/\Delta T$	Average temperature coefficient of input offset voltage	$T_A = T_{HIGH}$ to T_{LOW}		10			10			10		$\mu V/^\circ C$
BW _p	Power bandwidth	$A_V = 1$, $R_L = 2.0k\Omega$, $V_O = 20V_{P-P}$ THD = 5%		9.0			9.0			9.0		kHz
BW	Small-signal bandwidth	$A_V = 1$, $R_L = 10k\Omega$, $V_O = 50mV$		1.0			1.0			1.0		MHz
SR	Slew rate	$A_V = 1$, $V_I = -10V$ to $+10V$		0.6			0.6			0.6		$V/\mu s$
t_{TLH}	Rise time	$A_V = 1$, $R_L = 10k\Omega$, $V_O = 50mV$		0.35			0.35			0.35		μs
t_{THL}	Fall time	$A_V = 1$, $R_L = 10k\Omega$, $V_O = 50mV$		0.35			0.35			0.35		μs
OS	Overshoot	$A_V = 1$, $R_L = 10k\Omega$, $V_O = 50mV$		20			20			20		%
θ_m	Phase margin	$A_V = 1$, $R_L = 2.0k\Omega$, $C_L = 200pF$		50			50			50		Deg
	Crossover distortion	$V_{IN} = 30mV_{P-P}$, $V_{OUT} = 2.0V_{P-P}$, $f = 10kHz$		1.0			1.0			1.0		%

4

Quad Low Power Operational Amplifiers

MC3303/3403/3503

DC AND AC ELECTRICAL CHARACTERISTICS $V_{CC} = 5.0V$, $V_E = GND$, $T_A = 25^\circ C$, unless otherwise noted.

SYMBOL	PARAMETER	TEST CONDITIONS	MC3503			MC3403			MC3303			UNIT
			Min	Typ	Max	Min	Typ	Max	Min	Typ	Max	
V_{IO}	Input offset voltage			2.0	5.0		2.0	10.0			10.0	mV
I_{IO}	Input offset current			30	50		30	50			75	nA
I_{BIAS}	Input bias current			-200	-500		-200	-500			-500	nA
A_{VOL}	Large-signal open-loop voltage gain	$R_L = 2.0k\Omega$	10	200		10	200		10	200		V/mV
PSRR	Power supply rejection ratio				150			150			150	$\mu V/V$
V_{OR}	Output voltage range ²	$R_L = 10k\Omega$, $V_{CC} = 5.0V$ $R_L = 10k\Omega$, $5.0V \leq V_{CC} \leq 30V$	3.3	3.5		3.3	3.5		3.3	3.5		V_p
			$V_{CC} - 1.7$	$V_{CC} - 1.5$		$V_{CC} - 1.7$	$V_{CC} - 1.5$		$V_{CC} - 1.7$	$V_{CC} - 1.5$		
I_{CC}	Power supply current			2.5	4.0		2.5	7.0		2.5	7.0	mA
	Channel separation	$f = 1.0kHz$ to $20kHz$ (input referenced)		-120			-120			-120		dB

NOTES:

1. Not to exceed maximum package power dissipation.
2. Output will swing to ground.

Quad Low Power Operational Amplifiers

MC3303/3403/3503

TYPICAL PERFORMANCE CHARACTERISTICS

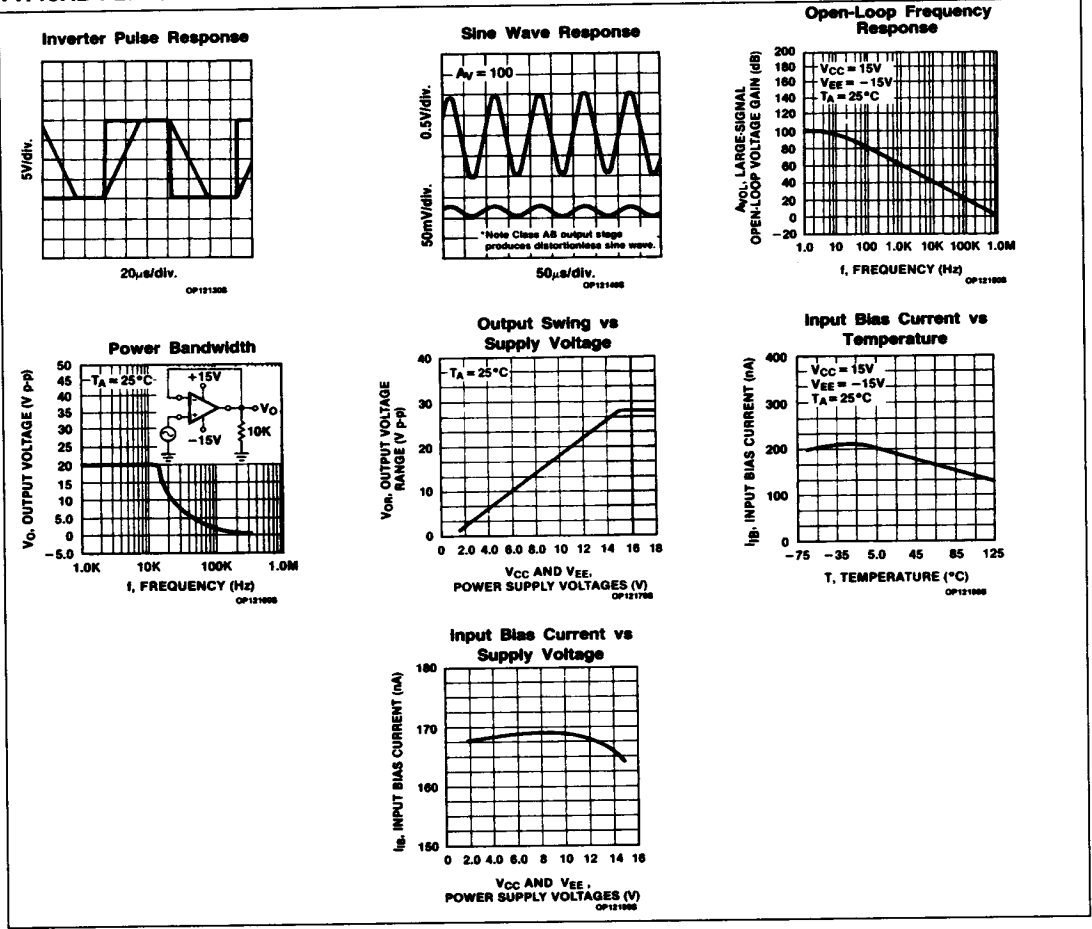

4