

27C1024

型名	社名	温度範囲 (℃)	スイッチング特性					電源		入力		出力/測定電流			備考 [*typ]
			TAAC max (ns)	TCAC max (ns)	T0H max (ns)	T0E max (ns)	T0D max (ns)	VDD (V)	I DD/STANDBY (mA)	VIL max (V)	VIH min (V)	CI max (pF)	VOL/IVOL max (V/mA)	VOH/IOH max (V/mA)	
M5M27C102K	MITSUBISHI	-10~80	250	250	0	100	60	4.75~5.25	50/1	0.8	2.0	15	0.45/2.1	2.4/0.4	15
M5M27C102K/JK-12	MITSUBISHI	-10~80	120	120	0	60	50	4.75~5.25	50/1	0.8	2.0	15	0.45/2.1	2.4/0.4	15
M5M27C102K/JK-15	MITSUBISHI	-10~80	150	150	0	60	50	4.75~5.25	50/1	0.8	2.0	15	0.45/2.1	2.4/0.4	15
M5M27C102K/JK-2	MITSUBISHI	-10~80	200	200	0	75	60	4.75~5.25	50/1	0.8	2.0	15	0.45/2.1	2.4/0.4	15
M5M27C102P	MITSUBISHI	-10~80	200	200	0	75	60	4.75~5.25	50/1	0.8	2.0	15	0.45/2.1	2.4/0.4	15
M5M27C102RV	MITSUBISHI	-10~80	200	200	0	75	60	4.75~5.25	50/1	0.8	2.0	15	0.45/2.1	2.4/0.4	15
M5M27C102VP	MITSUBISHI	-10~80	200	200	0	75	60	4.75~5.25	50/1	0.8	2.0	15	0.45/2.1	2.4/0.4	15
M6M271024-15	FUJITSU	0~70	150	150		70	60	4.5~5.5	40/1	0.8	2	12	0.45/2.1	2.4/0.4	12
M6M271024-20	FUJITSU	0~70	200	200		70	60	4.5~5.5	30/1	0.8	2	12	0.45/2.1	2.4/0.4	12
M6M271024-25	FUJITSU	0~70	250	250		100	60	4.5~5.5	30/1	0.8	2	12	0.45/2.1	2.4/0.4	12
M5M271024-12	OKI	0~70	120	120		50	40	4.75~5.25	100/35	0.8	2.0	12	0.45/2.1	2.4/0.4	15
M5M271024-15	OKI	0~70	150	150		60	50	4.75~5.25	100/35	0.8	2.0	12	0.45/2.1	2.4/0.4	15
M5M271024-17	OKI	0~70	170	170		60	50	4.75~5.25	100/35	0.8	2.0	12	0.45/2.1	2.4/0.4	15
NMC27C1024-120	NS	0~70	120	120		50	40	4.5~5.5	70/1	0.8	2.0	10	0.45/2.1	2.4/0.4	15
NMC27C1024-150	NS	0~70	150	150		60	50	4.5~5.5	70/1	0.8	2.0	10	0.45/2.1	2.4/0.4	15
NMC27C1024-200	NS	0~70	200	200		75	60	4.5~5.5	70/1	0.8	2.0	10	0.45/2.1	2.4/0.4	15
NMC27C1024-90	NS	0~70	90	90		40	40	4.5~5.5	70/1	0.8	2.0	10	0.45/2.1	2.4/0.4	15
NMC27C1024Q150	NS	0~70	150	150		60	50	4.5~5.5	30/1	0.8	2	20	0.4/2.1	3.5/2.5	20
NMC27C1024Q150	NS	0~70	150	150	0	60	50	4.5~5.5	30/1	0.8	2	12*	0.4/2.1	3.5/2.5	13*
NMC27C1024Q170	NS	0~70	170	170	0	75	55	4.5~5.5	30/1	0.8	2	12*	0.4/2.1	3.5/2.5	13*
NMC27C1024Q200	NS	0~70	200	200	0	75	55	4.5~5.5	30/1	0.8	2	12*	0.4/2.1	3.5/2.5	13*
NMC27C1024Q250	NS	0~70	250	250	0	100	60	4.5~5.5	30/1	0.8	2	12*	0.4/2.1	3.5/2.5	13*
TMS7H1024AD-100	TOSHIBA	0~70	100		10	50	50	4.5~5.5	40/1	0.8	2.2	16	0.4/2.1	2.4/0.4	16
TMS7H1024AD-85	TOSHIBA	0~70	85		5	45	30	4.75~5.25	40/1	0.8	2.2	16	0.4/2.1	2.4/0.4	16
TMS7H1024D-10	TOSHIBA	0~70	100		10	50	50	4.75~5.25	40/1	0.8	2.2	6*	0.4/2.1	2.4/0.4	10*
TMS7H1024D-100	TOSHIBA	0~70	100		10	50	50	4.5~5.5	40/1	0.8	2.2	6*	0.4/2.1	2.4/0.4	10*
TMS7H1024D-85	TOSHIBA	0~70	85		5	45	30	4.75~5.25	40/1	0.8	2.2	6*	0.4/2.1	2.4/0.4	10*
TMS7H1025AD-55	TOSHIBA	0~70	55		0	25	25	4.75~5.25	90/20	0.8	2.2	16	0.4/8.0	2.4/0.4	16
TMS7H1025AD-70	TOSHIBA	0~70	70		5	40	30	4.75~5.25	90/20	0.8	2.2	16	0.4/8.0	2.4/0.4	16
TMS27C210-170	TI	0~70	170	170	0	150	60	4.75~5.25	40/1	0.8	2.0	6*	0.4/2.1	2.4/2.0	10*
TMS27C210-20	TI	0~70	200	200	0	150	60	4.5~5.5	40/1	0.8	2.0	6*	0.4/2.1	2.4/2.0	10*
TMS27C210-200	TI	0~70	200	200	0	150	60	4.75~5.25	40/1	0.8	2.0	6*	0.4/2.1	2.4/2.0	10*
TMS27C210-25	TI	0~70	250	250	0	150	80	4.5~5.5	40/1	0.8	2.0	6*	0.4/2.1	2.4/2.0	10*
TMS27C210-250	TI	0~70	250	250	0	150	80	4.75~5.25	40/1	0.8	2.0	6*	0.4/2.1	2.4/2.0	10*
TMS27C210-30	TI	0~70	300	300	0	150	80	4.5~5.5	40/1	0.8	2.0	6*	0.4/2.1	2.4/2.0	10*
TMS27C210-300	TI	0~70	300	300	0	150	80	4.75~5.25	40/1	0.8	2.0	6*	0.4/2.1	2.4/2.0	10*
WS27C210L-100	WSI	0~70	100		0	30	30	4.5~5.5	70/1	0.8	2.0	4*	0.4/2.1	3.5/0.4	8*
WS27C210L-120	WSI	0~70	120		0	35	35	4.5~5.5	70/1	0.8	2.0	4*	0.4/2.1	3.5/0.4	8*
WS27C210L-150	WSI	0~70	150		0	40	40	4.5~5.5	70/1	0.8	2.0	4*	0.4/2.1	3.5/0.4	8*
WS27C210L-200	WSI	0~70	200		0	40	40	4.5~5.5	70/1	0.8	2.0	4*	0.4/2.1	3.5/0.4	8*
WS57C210F-55	WAFERSCALE	0~70	55	55	0	20	20	4.5~5.5	75/2	0.8	2	4*	0.4/8	2.4/2	8*
WS57C210F-55	WAFERSCALE	0~70	70	70		25	25	4.5~5.5	75/2	0.8	2	6	0.4/8	2.4/2	12

1M CMOS UV-EPROM (65,536×16) 40PIN

◆ピン接続

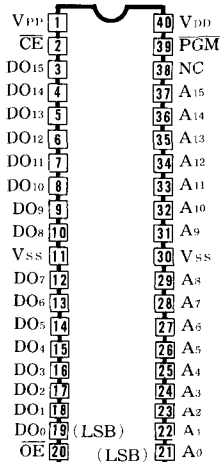

◆特徴

- ① 入出力はすべて TTL コンパチブル。
- ② データ出力 DO は 3 ステート。
- ③ 16ビット・データライン (16 bit CPU に最適)。
- ④ テップ出力は 1 本で出力イネーブルあり。

◆ブロック図

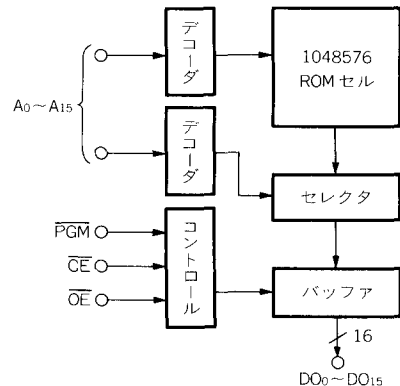

◆波形

① READ ($\overline{OE}=L$)

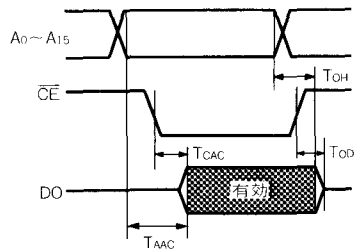

② READ ($\overline{CS}=L$)

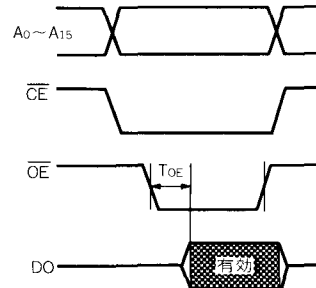

◆電源

V_{DD} : +5V Pin40
 V_{SS} (GND) : Pin11, 30
 PGM : Pin39
 V_{PP} : Pin 1

◆動作表

入 力			DO	動 作
CE	OE	PGM		
L	L	H	DO	Read
L	H	H	High-Z	Outputs Disable
H	X	X	High-Z	Stand-by