

Low-Power, Slew-Rate-Limited RS-485/RS-422 Transceivers

ILX485

Description

The ILX485 is low-power transceivers for RS-485 and RS- 422 communication. IC contains one driver and one receiver.

The driver slew rates of the ILX485 is not limited, allowing them to transmit up to 10 Mbps.

These transceivers draw between 120µA and 500µA of supply current when unloaded or fully loaded with disabled drivers. All parts operate from a single 5V supply. Drivers are short-circuit current limited and are protected against excessive power dissipation by thermal shutdown circuitry that places the driver outputs into a high-impedance state.

The receiver input has a fail-safe feature that guarantees a logic-high output if the input is open circuit. The ILX485 is designed for half-duplex applications.

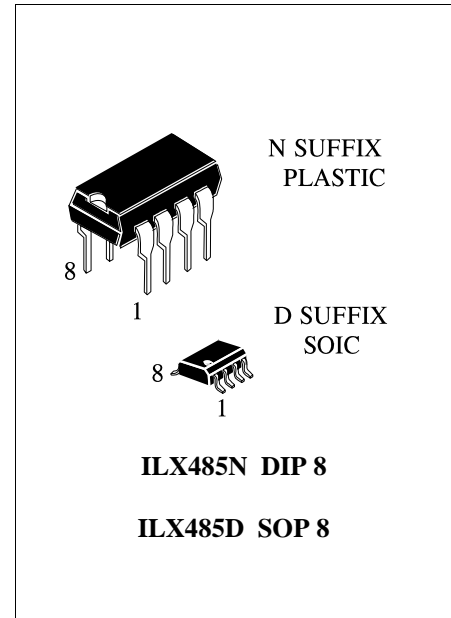

ORDERING INFORMATION

Device	Operating Temperature Range	Package	Shipping
ILX485N	T _A = -40° to 85° C	DIP8	Tube
ILX485D		SOP8	Tube
ILX485DT		SOP8	Tape & Reel

Features

- Low Quiescent Current: 300µA
- -7V to +12V Common-Mode Input Voltage Range
- Three-State Outputs
- 50ns Propagation Delays, 5ns Skew
- Full-Duplex and Half-Duplex Versions Available
- Operate from a Single 5V Supply
- Allows up to 32 Transceivers on the Bus
- Data rate: 10 Mbps
- Current-Limiting and Thermal Shutdown for Driver Overload Protection
- Enhanced ESD Specifications:
 - ±15kV IEC61000-4-2 Air Discharge
 - ±8kV IEC61000-4-2 Contact Discharge

Pin Description

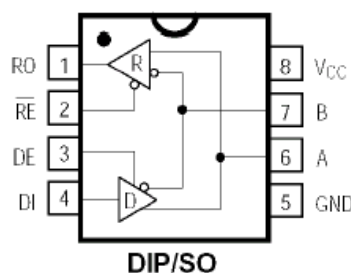

ABSOLUTE MAXIMUM RATINGS

Supply Voltage (V_{CC}) 12V	Continuous Power Dissipation ($T_A = +70^\circ\text{C}$)
Control Input Voltage -0.5V to ($V_{CC} + 0.5\text{V}$)	8-Pin Plastic DIP (derate 9.09mW/ $^\circ\text{C}$ above $+70^\circ\text{C}$) 727mW
Driver Input Voltage (DI) -0.5V to ($V_{CC} + 0.5\text{V}$)	8-Pin SOP (derate 5.88mW/ $^\circ\text{C}$ above $+70^\circ\text{C}$) 471mW
Driver Output Voltage (A, B) -8V to +12.5V	Operating Temperature Ranges -40°C to $+85^\circ\text{C}$
Receiver Input Voltage (A, B) -8V to +12.5V	Storage Temperature Range -65°C to $+160^\circ\text{C}$
Receiver Output Voltage (RO) -0.5V to ($V_{CC} + 0.5\text{V}$)	Lead Temperature (soldering, 10sec) $+300^\circ\text{C}$

* Stresses beyond those listed under “absolute maximum ratings” may cause permanent damage to the device. These are stress ratings only and functional operation of the device at these or any other conditions beyond those indicated under “recommended operating conditions” is not implied. Exposure to absolute-maximum-rated conditions for extended periods may affect device reliability.

DC ELECTRICAL CHARACTERISTICS

($V_{CC} = 5\text{V} \pm 5\%$, $T_A = T_{MIN}$ to T_{MAX} , unless otherwise noted.) (Notes 1, 2)

PARAMETER	SYMBOL	CONDITIONS	MIN	TYP	MAX	UNITS
Differential Driver Output (no load)	V_{OD1}				5	V
Differential Driver Output (with load)	V_{OD2}	R = 50 Ω (RS-422)	2			V
		R = 27 Ω (RS-485), Figure 1	1.5		5	
Change in Magnitude of Driver Differential Output Voltage for Complementary Output States	ΔV_{OD}	R = 27 Ω or 50 Ω , Figure 1			0.2	V
Driver Common-Mode Output Voltage	V_{OC}	R = 27 Ω or 50 Ω , Figure 1			3	V
Change in Magnitude of Driver Common-Mode Output Voltage for Complementary Output States	ΔV_{OD}	R = 27 Ω or 50 Ω , Figure 1			0.2	V
Input High Voltage	V_{IH}	DE, DI, RE	2.0			V
Input Low Voltage	V_{IL}	DE, DI, RE			0.8	V
Input Current	I_{IN1}	DE, DI, RE			± 2	μA
Input Current (A, B)	I_{IN2}	DE = 0V; $V_{CC} = 0\text{V}$ or 5.25V	$V_{IN} = 12\text{V}$		1.0	mA
			$V_{IN} = -7\text{V}$		-0.8	
Receiver Differential Threshold Voltage	V_{TH}	$-7\text{V} \leq V_{CM} \leq 12\text{V}$	-0.2		0.2	V
Receiver Input Hysteresis	ΔV_{TH}	$V_{CM} = 0\text{V}$		70		mV
Receiver Output High Voltage	V_{OH}	$I_o = -4\text{mA}$, VID = 200mV	3.5			V
Receiver Output Low Voltage	V_{OL}	$I_o = 4\text{mA}$, VID = -200mV			0.4	V
Three-State (high impedance) Output Current at Receiver	I_{OZR}	$0.4\text{V} \leq V_o \leq 2.4\text{V}$			± 1	μA
Receiver Input Resistance	R_{IN}	$-7\text{V} \leq V_{CM} \leq 12\text{V}$	12			k Ω

DC ELECTRICAL CHARACTERISTICS (continue)

 (V_{CC} = 5V ±5%, T_A = T_{MIN} to T_{MAX}, unless otherwise noted.) (Notes 1, 2)

PARAMETER	SYMBOL	CONDITIONS	MIN	TYP	MAX	UNITS
No-Load Supply Current (Note 3)	I _{CC}	DE = V _{CC}		500	900	
		RE = 0V or V _{CC}		300	500	μA
		DE = 0V				
Driver Short-Circuit Current	I _{OSD1}	-7V ≤ V _O ≤ 12V (Note 4)	35		250	mA
VO = High Driver Short-Circuit Current	I _{OSD2}	-7V ≤ V _O ≤ 12V (Note 4)	35		250	mA
VO = Low Receiver Short-Circuit Current	I _{OSR}	0V ≤ V _O ≤ V _{CC}	7		95	mA
ESD Protection		A, B, Y and Z pins, tested using Human Body Model		±15		kV

SWITCHING CHARACTERISTICS

 (V_{CC} = 5V ±5%, T_A = T_{MIN} to T_{MAX}, unless otherwise noted.) (Notes 1, 2)

PARAMETER	SYMBOL	CONDITIONS	MIN	TYP	MAX	UNITS
Driver Input to Output	t _{PLH}	R _{DIFF} = 54Ω	10	55	60	ns
	t _{PHL}	C _{L1} = C _{L2} = 100pF	10	55	60	
Driver Output Skew to Output	t _{SKEW}	R _{DIFF} = 54Ω, C _{L1} = C _{L2} = 100pF		5	10	ns
Driver Enable to Output High	t _{ZH}	C _L = 100pF, S2 closed		40	70	ns
Driver Enable to Output Low	t _{ZL}	C _L = 100pF, S1 closed		40	70	ns
Driver Disable Time from Low	t _{LZ}	C _L = 15pF, S1 closed		40	70	ns
Driver Disable Time from High	t _{HZ}	C _L = 15pF, S2 closed		40	70	ns
Receiver Input to Output	t _{PLH}	R _{DIFF} = 54Ω	20	60	100	ns
	t _{PHL}	C _{L1} = C _{L2} = 100pF	20	60	100	
t _{PLH} - t _{PHL} Differential Receiver Skew	t _{SKD}	R _{DIFF} = 54Ω C _{L1} = C _{L2} = 100pF		5	10	ns
Receiver Enable to Output Low	t _{ZL}	C _{RL} = 15pF, S1 closed		30	50	ns
Receiver Enable to Output High	t _{ZH}	C _{RL} = 15pF, S2 closed		30	50	ns
Receiver Disable Time from Low	t _{LZ}	C _{RL} = 15pF, S1 closed		30	50	ns
Receiver Disable Time from High	t _{HZ}	C _{RL} = 15pF, S2 closed		30	50	ns
Maximum Data Rate	f _{MAX}		2.5	10	20	Mbps

Note 1: All currents into device pins are positive; all currents out of device pins are negative. All voltages are referenced to device ground unless otherwise specified.

Note 2: All typical specifications are given for V_{CC}=5V and T_A=+25°C.

Note 3: Supply current specification is valid for loaded transmitters when DE=0V.

Note 4: Applies to peak current.

TEST CIRCUITS

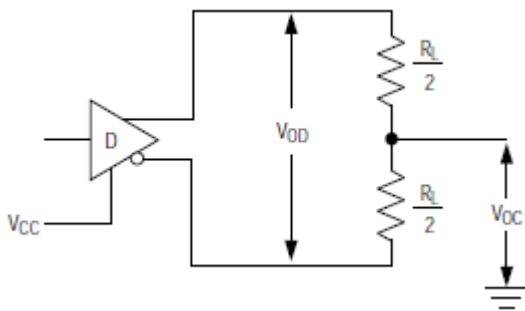

Figure 1. Driver V_{OD} and V_{OC}

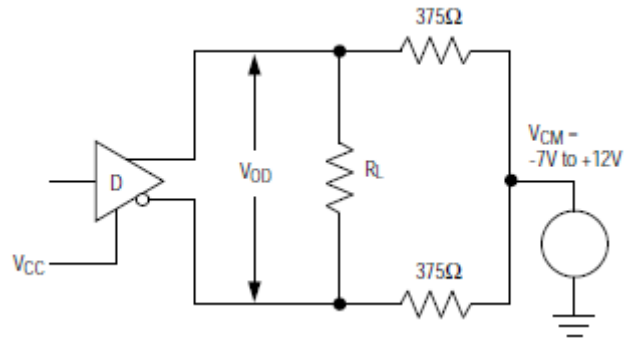

Figure 2. Driver V_{OD} with Varying Common-Mode Voltage

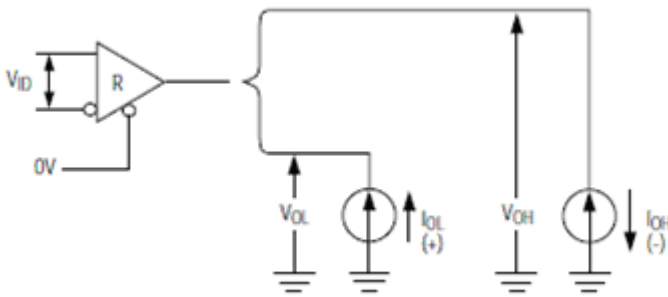

Figure 3. Receiver V_{OH} and V_{OL}

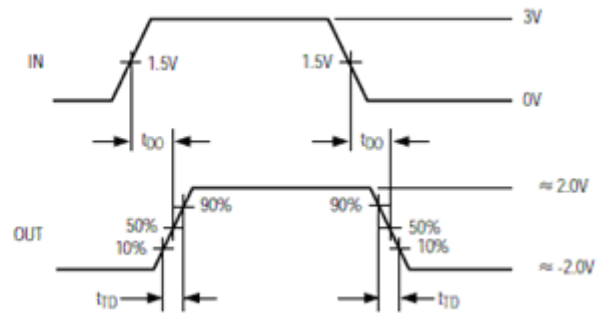
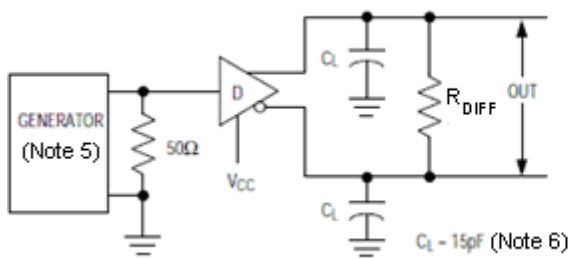

Figure 4. Driver Differential Output Delay and Transition Times

TEST CIRCUITS (continue)

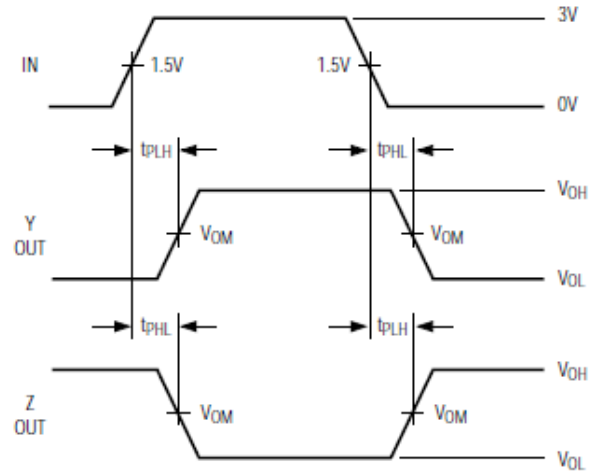
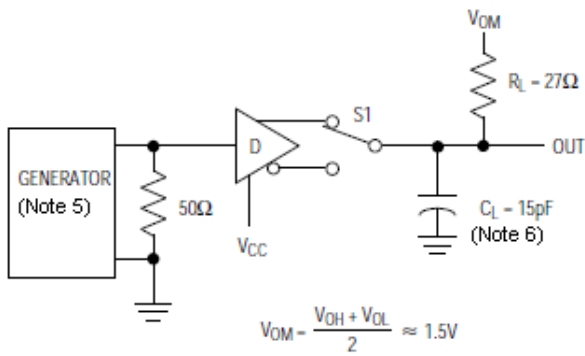

Figure 5. Driver Propagation Times

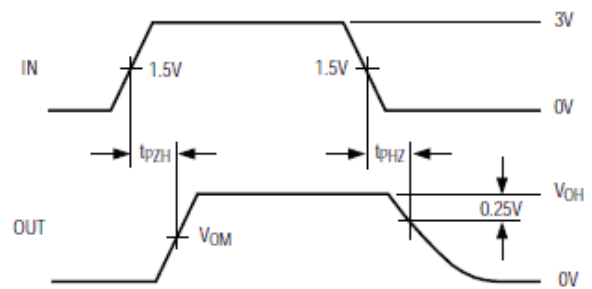
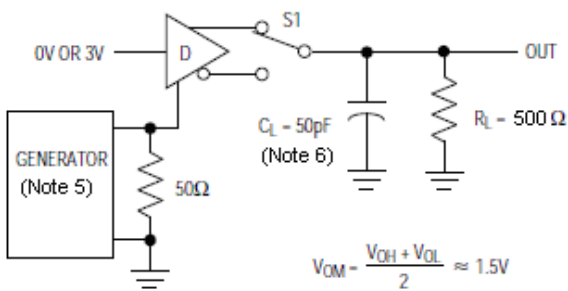

Figure 6. Driver Enable and Disable Times (t_{PZH} , t_{PSH} , t_{PHZ})

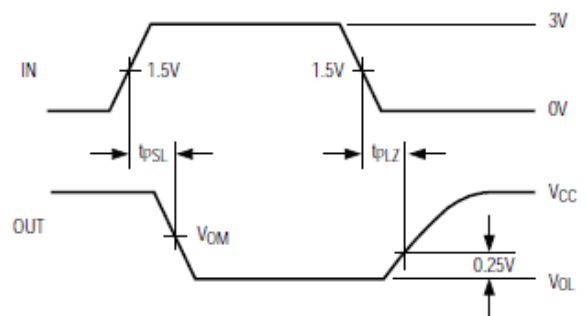
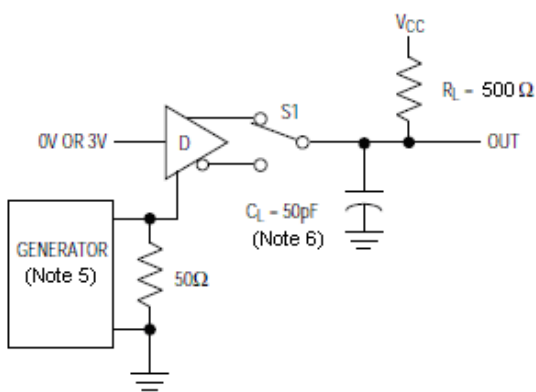

Figure 7. Driver Enable and Disable Times (t_{PZL} , t_{PSL} , t_{PLZ})

TEST CIRCUITS (continue)

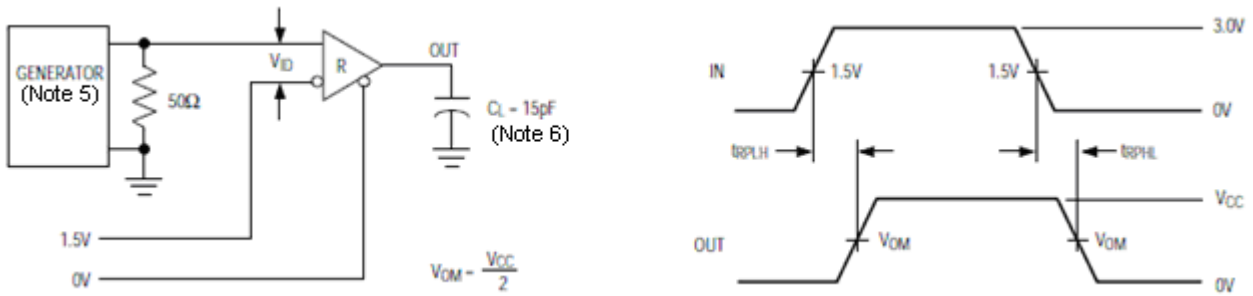

Figure 8. Receiver Propagation Delay

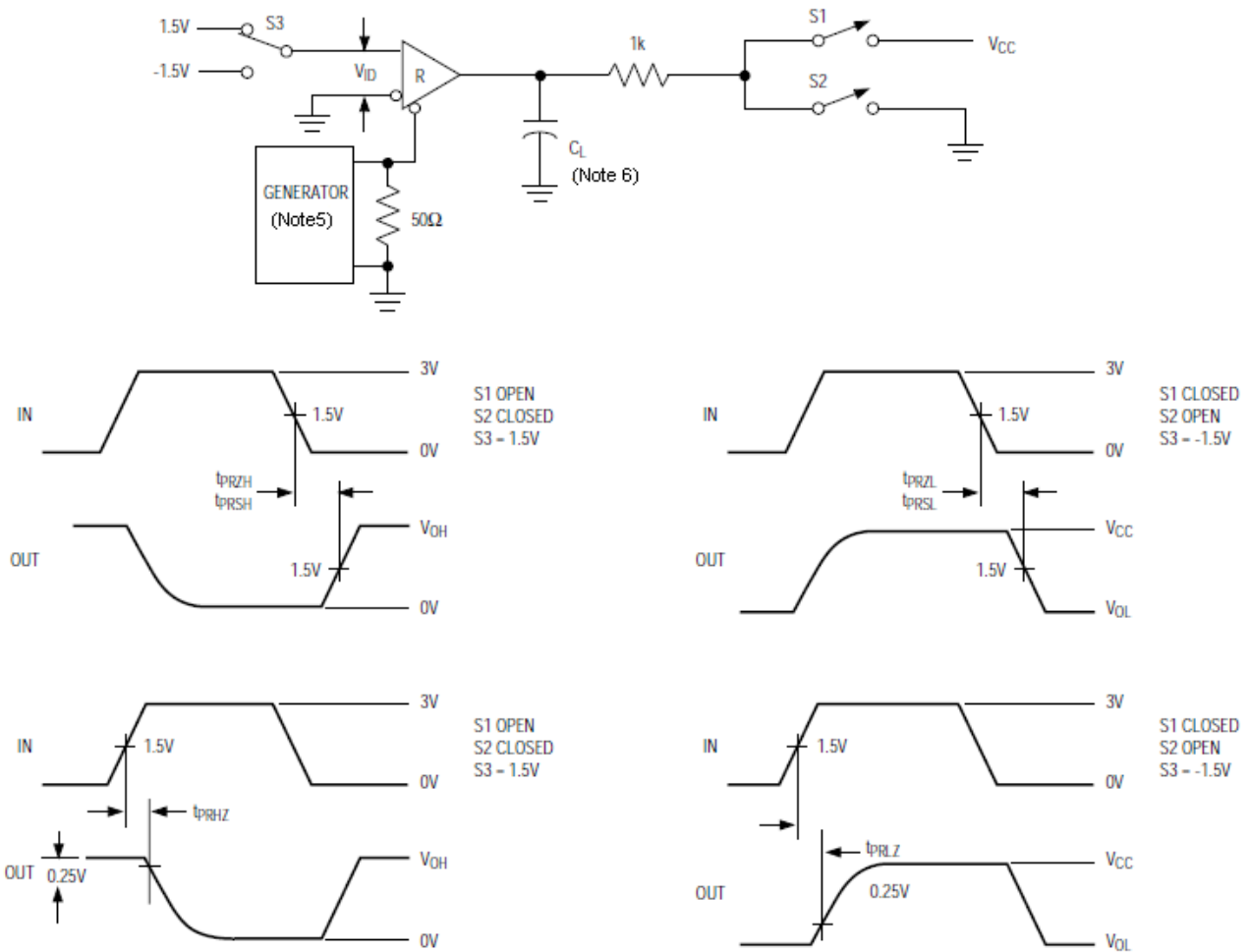

Figure 9. Receiver Enable and Disable Times

Note 5: The input pulse is supplied by a generator with the following characteristics: PRR = 250kHz, 50% duty cycle, $t_r \leq 6.0\text{ns}$, $Z_o = 50\Omega$.

Note 6: C_L includes probe and stray capacitance.

Function Tables

Transmitting				
INPUTS			OUTPUTS X	
RE	DE	DI	Z	Y
X	1	1	0	1
X	1	0	1	0
0	0	X	Z	Z
1	0	X	Z	Z

Receiving			
INPUTS			OUTPUTS
RE	DE	A-B	RO
0	0	+0.2V	1
0	0	-0.2V	0
0	0	open	1
1	0	X	Z

X-don't care
Z-high impedance

Typical Information

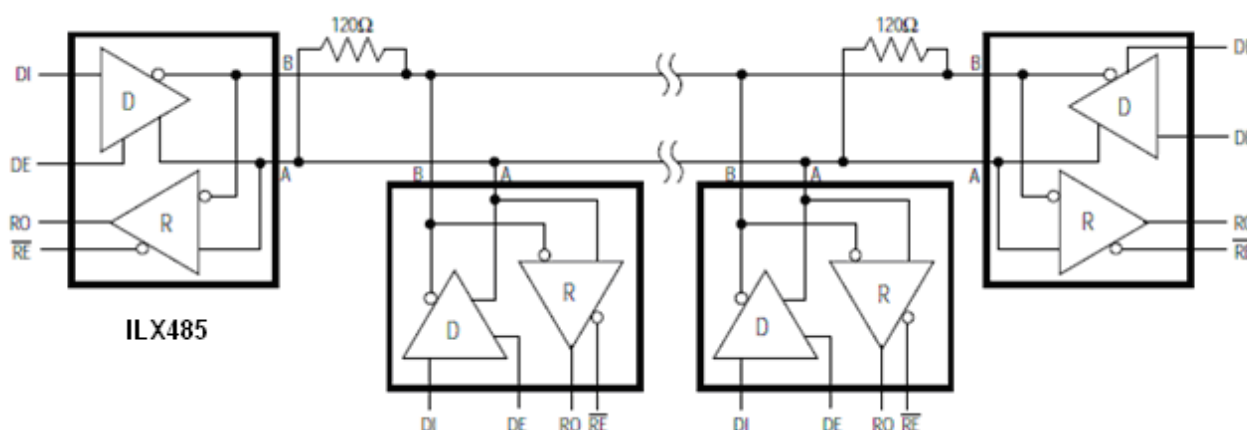

Figure 10. ILX485 Typical RS-485 Network

Driver Output Protection

Excessive output current and power dissipation caused by faults or by bus contention are prevented by two mechanisms. A foldback current limit on the output stage provides immediate protection against short circuits over the whole common-mode voltage range. In addition, a thermal shutdown circuit forces the driver outputs into a high-impedance state if the die temperature rises excessively.

Propagation Delay

Skew time is simply the difference between the low-to-high and high-to-low propagation delay. Small driver/receiver skew times help maintain a symmetrical mark-space ratio (50% duty cycle).

The receiver skew time, $|t_{PRLH} - t_{PRHL}|$, is under 10ns. The driver skew times are 5ns for the ILX485.

Typical Applications

ILX485 transceivers are designed for bidirectional data communications on multipoint bus transmission lines. Figure 10 shows typical network applications circuits. These parts can also be used as line repeaters, with cable lengths longer than 4000 feet.

To minimize reflections, the line should be terminated at both ends in its characteristic impedance, and stub lengths off the main line should be kept as short as possible.

Package Dimensions

N SUFFIX PLASTIC DIP
(MS - 001BA)

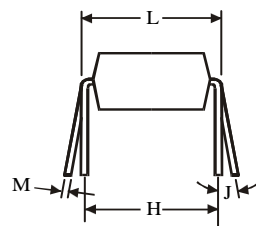
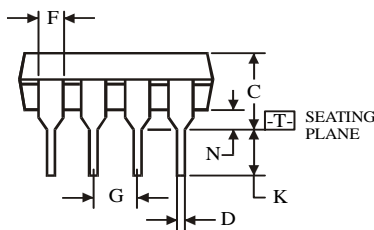
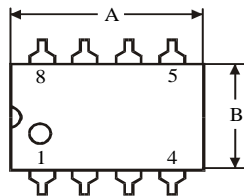
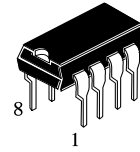

$\oplus 0.25 (0.010) \text{ (M) } | \text{ T}$

Symbol	Dimension, mm	
	MIN	MAX
A	8.51	10.16
B	6.1	7.11
C		5.33
D	0.36	0.56
F	1.14	1.78
G	2.54	
H	7.62	
J	0°	10°
K	2.92	3.81
L	7.62	8.26
M	0.2	0.36
N	0.38	

NOTES:

- Dimensions "A", "B" do not include mold flash or protrusions.
Maximum mold flash or protrusions 0.25 mm (0.010) per side.

D SUFFIX SOIC
(MS - 012AA)

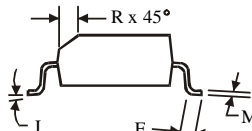
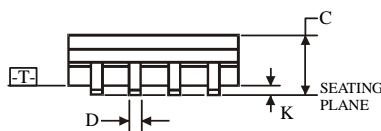
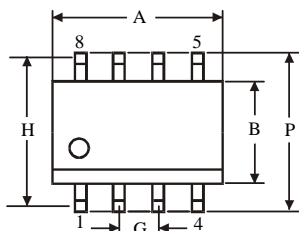
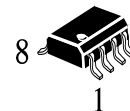

$\oplus 0.25 (0.010) \text{ (M) } | \text{ T } | \text{ C (M)}$

Symbol	Dimension, mm	
	MIN	MAX
A	4.8	5
B	3.8	4
C	1.35	1.75
D	0.33	0.51
F	0.4	1.27
G	1.27	
H	5.72	
J	0°	8°
K	0.1	0.25
M	0.19	0.25
P	5.8	6.2
R	0.25	0.5

NOTES:

- Dimensions A and B do not include mold flash or protrusion.
- Maximum mold flash or protrusion 0.15 mm (0.006) per side
for A; for B - 0.25 mm (0.010) per side.