

REV. A	DESCRIPTION NEW DRAWING	DATE 1/9/2008
-----------	----------------------------	------------------

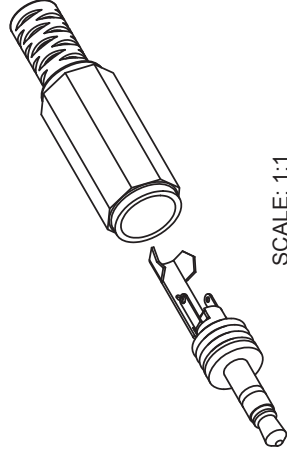

SCALE: 1:1

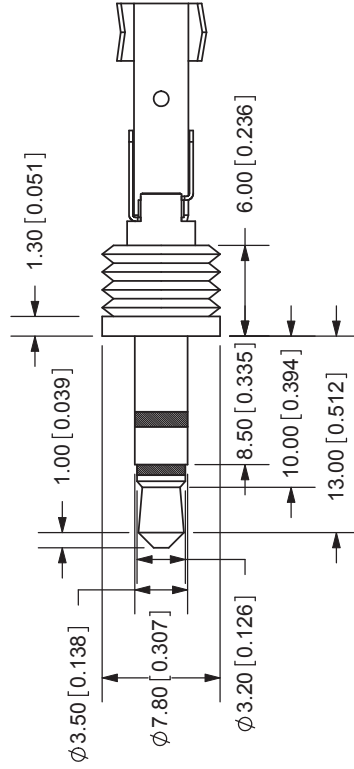
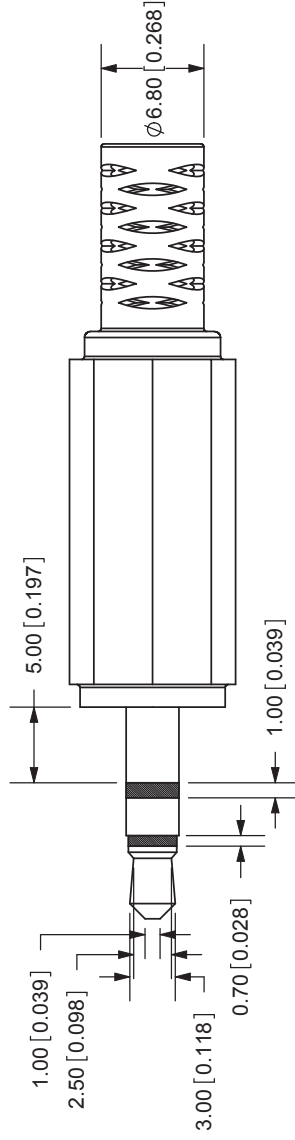

TOLERANCE:
±0.3mm UNLESS OTHERWISE
SPECIFIED

SPECIFICATIONS:
CONTACT RESISTANCE: 30m OHMS MAX
INSULATION RESISTANCE: 100M OHMS MIN: 500V DC
VOLTAGE WITHSTAND: 500V AC R.M.S. FOR 1 MINUTE
LIFE: 5,000 CYCLES
OPERATING TEMP: -20° ~ +85°C

	MATERIAL	PLATING
RING TERMINAL	Brass	Nickel
TIP TERMINAL	Brass	Nickel
EARTH TERMINAL	Brass	Nickel
SLEEVE	Brass	Nickel
CONTACT HEAD	Brass	Nickel
INSULATOR	POM	black color
BODY	PE	black color



20050 SW 112th Ave.
Tualatin, OR 97062
Phone: 503-612-2300
800-275-4899
Fax: 503-612-2383
Website: www.cui.com

TITLE: 3.5mm STEREO PLUG	REV: A
PART NO: SP-3501	UNITS: MM [INCHES]
DRAWN BY: ZRJ	APPROVED BY:
	SCALE: 2:1