

## NMC93C06/C26/C46 256-Bit/512-Bit/1024-Bit Serial Electrically Erasable Programmable Memory

### General Description

The NMC93C06/NMC93C26/NMC93C46 are 256/512/1024 bits of CMOS electrically erasable memory divided into 16-bit registers. They are fabricated using National Semiconductor's floating-gate CMOS process for high speed and low power. They operate from a single 5V supply since  $V_{PP}$  is generated on-board. The serial organization allows the NMC93C06/NMC93C26/NMC93C46 to be packaged in an 8-pin DIP or 14-pin SO package to save board space.

The memories feature a serial interface with the instruction, address, and write data, input on the Data-In (DI) pin. All read data and device status is output on the Data-Out (DO) pin. A low-to-high transition of shift clock (SK) shifts all data in and out. This serial interface is MICROWIRE™ compatible for simple interface to standard microcontrollers and microprocessors. There are 7 instructions: Read, Erase/Write Enable, Erase, Erase All, Write, Write All, Erase/Write Disable. The NMC93C06/NMC93C26/NMC93C46 do not require an erase cycle prior to the Write and Write All instructions. The Erase and Erase All instructions are available to maintain complete read and programming compatibility with the NMOS NMC9346. All programming cycles are completely self-timed for simplified operation. The busy status is available on the DO pin to indicate the completion of a programming cycle. EEPROMs are shipped in the erased state where all bits are logical 1's.

### Compatibility with Other Devices

These memories are pin compatible to National Semiconductor's NMOS EEPROMs, NMC9306 and NMC9346. The NMC93C06/NMC93C26/NMC93C46 are both pin and function compatible with the NMC93C56 2048-bit EEPROM and the NMC93C66 4096-bit EEPROM with the one exception that both of these larger devices require two additional address bits.

### Features

- Typical active current 400  $\mu$ A; Typical standby current 25  $\mu$ A
- Reliable CMOS floating gate technology
- 5V only operation in all modes
- MICROWIRE compatible serial I/O
- Self-timed programming cycle
- Device status signal during programming mode
- Over 10 years data retention
- Typically 40,000 writes

### Block Diagram

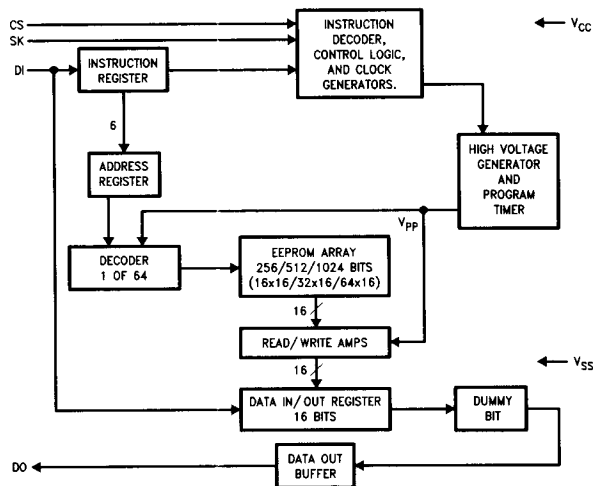

TL/D/8790-3

## Connection Diagrams

### Dual-In-Line Package (N)

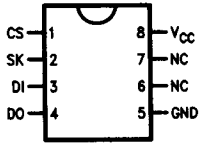

TL/D/8790-1

Top View

See NS Package Number N08E

### Pin Names

CS Chip Select  
SK Serial Data Clock  
DI Serial Data Input  
DO Serial Data Output  
GND Ground  
V<sub>CC</sub> Power Supply

### SO Package (M)

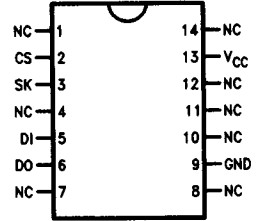

TL/D/8790-2

Top View

See NS Package Number M14A

## Ordering Information

### Commercial Temp. Range (0°C to +70°C)

V<sub>CC</sub> = 5V ± 10%

#### Order Number

NMC93C06N/NMC93C26N/  
NMC93C46N  
NMC93C06M/NMC93C26M/  
NMC93C46M

### Extended Temp. Range (-40°C to +85°C)

V<sub>CC</sub> = 5V ± 10%

#### Order Number

NMC93C06EN/NMC93C26EN/  
NMC93C46EN  
NMC93C06EM/NMC93C26EM/  
NMC93C46EM

### Military Temp. Range (-55°C to +125°C)

#### Order Number

NMC93C06MN/NMC93C26MN/  
NMC93C46MN  
NMC93C06MM/NMC93C26MM/  
NMC93C46MM

**Absolute Maximum Ratings** (Note 1)

If Military/Aerospace specified devices are required, contact the National Semiconductor Sales Office/Distributors for availability and specifications.

All Input or Output Voltages with Respect to Ground	+6.5V to -0.3V
Ambient Storage Temperature	-65°C to +150°C
Lead Temperature (Soldering, 10 seconds)	+300°C
ESD rating	2000V

**Operating Conditions**

Ambient Operating Temperature	0°C to +70°C
NMC93C06/26/46	-40°C to +85°C
NMC93C06/26/46E	-55°C to +125°C
NMC93C06/26/46M	
Positive Supply Voltage	4.5V to 5.5V

**DC and AC Electrical Characteristics**  $V_{CC} = 5V \pm 10\%$  unless otherwise specified

Symbol	Parameter	Part Number	Conditions	Min	Max	Units
$I_{CC1}$	Operating Current CMOS Input Levels	NMC93C06/26/46	CS = $V_{IH}$ , SK = 1 MHz		2	mA
		NMC93C06/26/46E	SK = 0.5 MHz		2	
		NMC93C06/26/46M*	SK = 0.5 MHz		2	
$I_{CC2}$	Operating Current TTL Input Levels	NMC93C06/26/46	CS = $V_{IH}$ , SK = 1 MHz		3	mA
		NMC93C06/26/46E	SK = 0.5 MHz		3	
		NMC93C06/26/46M	SK = 0.5 MHz		4	
$I_{CC3}$	Standby Current	NMC93C06/26/46	CS = 0V		50	$\mu$ A
		NMC93C06/26/46E			100	
		NMC93C06/26/46M			100	
$I_{IL}$	Input Leakage	NMC93C06/26/46	$V_{IN} = 0V$ to $V_{CC}$	-2.5	2.5	$\mu$ A
		NMC93C06/26/46E		-10	10	
		NMC93C06/26/46M		-10	10	
$I_{OL}$	Output Leakage	NMC93C06/26/46	$V_{OUT} = 0V$ to $V_{CC}$	-2.5	2.5	$\mu$ A
		NMC93C06/26/46E		-10	10	
		NMC93C06/26/46M		-10	10	
$V_{IL}$ $V_{IH}$	Input Low Voltage Input High Voltage			-0.1 2	0.8 $V_{CC} + 1$	V
$V_{OL1}$ $V_{OH1}$	Output Low Voltage Output High Voltage		$I_{OL} = 2.1$ mA $I_{OH} = -400$ $\mu$ A		0.4	V
				2.4		
$V_{OL2}$ $V_{OH2}$	Output Low Voltage Output High Voltage		$I_{OL} = 10$ $\mu$ A $I_{OH} = -10$ $\mu$ A		0.2	V
				$V_{CC} - 0.2$		
$f_{SK}$	SK Clock Frequency	NMC93C06/26/46		0	1	MHz
		NMC93C06/26/46E		0	0.5	
		NMC93C06/26/46M		0	0.5	
$t_{SKH}$	SK High Time	NMC93C06/26/46	(Note 2)	250		ns
		NMC93C06/26/46E	(Note 3)	500		
		NMC93C06/26/46M	(Note 3)	500		
$t_{SKL}$	SK Low Time	NMC93C06/26/46	(Note 2)	250		ns
		NMC93C06/26/46E	(Note 3)	500		
		NMC93C06/26/46M	(Note 3)	500		
$t_{CS}$	Minimum CS Low Time	NMC93C06/26/46	(Note 4)	250		ns
		NMC93C06/26/46E	(Note 5)	500		
		NMC93C06/26/46M	(Note 5)	500		
$t_{CSS}$	CS Setup Time	NMC93C06/26/46	Relative to SK	50		ns
		NMC93C06/26/46E		100		
		NMC93C06/26/46M		100		

\*Note: Thruout this table "M" refers to temperature range (-55°C to +125°C), not package.

## DC and AC Electrical Characteristics $V_{CC} = 5V \pm 10\%$ (Continued)

Symbol	Parameter	Part Number	Conditions	Min	Max	Units
$t_{DIS}$	DI Setup Time	NMC93C06/26/46	Relative to SK	100		ns
		NMC93C06/26/46E		200		
		NMC93C06/26/46M		200		
$t_{CSH}$	CS Hold Time		Relative to SK	0		ns
$t_{DIH}$	DI Hold Time	NMC93C06/26/46	Relative to SK	100		ns
		NMC93C06/26/46E		200		
		NMC93C06/26/46M		200		
$t_{PD1}$	Output Delay to "1"	NMC93C06/26/46	AC Test		500	ns
		NMC93C06/26/46E		1000		
		NMC93C06/26/46M		1000		
$t_{PD0}$	Output Delay to "0"	NMC93C06/26/46	AC Test		500	ns
		NMC93C06/26/46E		1000		
		NMC93C06/26/46M		1000		
$t_{SV}$	CS to Status Valid	NMC93C06/26/46	AC Test		500	ns
		NMC93C06/26/46E		1000		
		NMC93C06/26/46M		1000		
$t_{DF}$	CS to DO in TRI-STATE®	NMC93C06/26/46	CS = $V_{IL}$ AC Test		100	ns
		NMC93C06/26/46E		200		
		NMC93C06/26/46M		200		
$t_{WP}$	Write Cycle Time				10	ms
	Endurance		Number of Data Changes per Bit	Typical 40,000		Cycles

**Note 1:** Stress above those listed under "Absolute Maximum Ratings" may cause permanent damage to the device. This is a stress rating only and functional operation of the device at these or any other conditions above those indicated in operational sections of the specification is not implied. Exposure to absolute maximum rating conditions for extended periods may affect device reliability.

**Note 2:** The SK frequency specification for Commercial parts specifies a minimum SK clock period of 1  $\mu$ s, therefore in an SK clock cycle  $t_{SKH} + t_{SKL}$  must be greater than or equal to 1  $\mu$ s. For example if  $t_{SKL} = 250$  ns then the minimum  $t_{SKH} = 750$  ns in order to meet the SK frequency specification.

**Note 3:** The SK frequency specification for Extended Temperature and Military parts specifies a minimum SK clock period of 2  $\mu$ s, therefore in an SK clock cycle  $t_{SKH} + t_{SKL}$  must be greater than or equal to 2  $\mu$ s. For example, if  $t_{SKL} = 500$  ns then the minimum  $t_{SKH} = 1.5$   $\mu$ s in order to meet the SK frequency specification.

**Note 4:** For Commercial parts CS must be brought low for a minimum of 250 ns ( $t_{CS}$ ) between consecutive instruction cycles.

**Note 5:** For Extended Temperature and Military parts CS must be brought low for a minimum of 500 ns ( $t_{CS}$ ) between consecutive instruction cycles.

**Note 6:** This parameter is periodically sampled and not 100% tested.

### Capacitance (Note 6)

$T_A = 25^\circ\text{C}$ ,  $f = 1$  MHz

Symbol	Test	Typ	Max	Units
$C_{OUT}$	Output Capacitance		5	pF
$C_{IN}$	Input Capacitance		5	pF

### AC Test Conditions

Output Load 1 TTL Gate and  $C_L = 100$  pF

Input Pulse Levels 0.4V to 2.4V

Timing Measurement Reference Level

Input 1V and 2V

Output 0.8V and 2V

## Functional Description

The NMC93C06/NMC93C26/NMC93C46 has 7 instructions as described below. Note that the MSB of any instruction is a "1" and is viewed as a start bit in the interface sequence. The next 8 bits carry the op code and the 6-bit address for selection of 1 of 16, 32, or 64 16-bit registers.

### Read (READ):

The Read (READ) instruction outputs serial data on the DO pin. After a READ instruction is received, the instruction and address are decoded, followed by data transfer from the selected memory register into a 16-bit serial-out shift register. A dummy bit (logical "0") precedes the 16-bit data output string. Output data changes are initiated by a low-to-high transition of the SK clock.

### Erase/Write Enable (EWEN):

When V<sub>CC</sub> is applied to the part, it "powers up" in the Erase/Write Disable (EWDS) state. Therefore, all programming modes must be preceded by an Erase/Write Enable (EWEN) instruction. Once an Erase/Write Enable instruction is executed, programming remains enabled until an Erase/Write Disable (EWDS) instruction is executed or V<sub>CC</sub> is removed from the part.

### Erase (ERASE):

The ERASE instruction will program all bits in the specified register to the logical "1" state. CS is brought low following the loading of the last address bit. This falling edge of the CS pin initiates the self-timed programming cycle.

The DO pin indicates the READY/BUSY status of the chip if CS is brought high after a minimum of 250 ns (t<sub>CS</sub>). DO = logical "0" indicates that programming is still in progress. DO = logical "1" indicates that the register, at the address specified in the instruction, has been erased, and the part is ready for another instruction.

### Write (WRITE)

The Write (WRITE) instruction is followed by 16 bits of data to be written into the specified address. After the last bit of data is clocked in on the data-in (DI) pin, CS must be brought low before the next rising edge of the SK clock. This falling edge of the CS initiates the self-timed programming cycle. The DO pin indicates the READY/BUSY status of the chip if CS is brought high after a minimum of 250 ns (t<sub>CS</sub>). DO = logical "0" indicates that programming is still in progress. DO = logical "1" indicates that the register at the address specified in the instruction has been written with the data pattern specified in the instruction and the part is ready for another instruction.

### Erase All (ERAL)

The ERAL instruction will simultaneously program all registers in the memory array and set each bit to the logical "1" state. The Erase All cycle is identical to the ERASE cycle except for the different op-code.

As in the ERASE mode, the DO pin indicates the READY/BUSY status of the chip if CS is brought high after a minimum of 250 ns (t<sub>CS</sub>).

### Write All (WRAL):

The WRAL instruction will simultaneously program all registers with the data pattern specified in the instruction. As in the WRITE mode, the DO pin indicates the READY/BUSY status of the chip if CS is brought high after a minimum of 50 ns (t<sub>CS</sub>).

### Erase/Write Disable (EWDS):

To protect against accidental data disturb, the Erase/Write Disable (EWDS) instruction disables all programming modes and should follow all programming operations. Execution of a READ instruction is independent of both the EWEN and EWDS instructions.

## Instruction Set for the NMC93C06/26/46

Instruction	SB	Op Code	Address	Data	Comments
READ	1	10	A5-A0		Reads data stored in memory, starting at specific 1 address.
EWEN	1	00	11XXXX		Write enable must precede all programming modes.
ERASE	1	11	A5-A0		Erase register A5A4A3A2A1A0.
WRITE	1	01	A5-A0	D15-D0	Writes register.
ERAL	1	00	10XXXX		Erase all registers.
WRAL	1	00	01XXXX	D15-D0	Writes all registers.
EWDS	1	00	00XXXX		Disables all programming instructions.

# Timing Diagrams

## Synchronous Data Timing

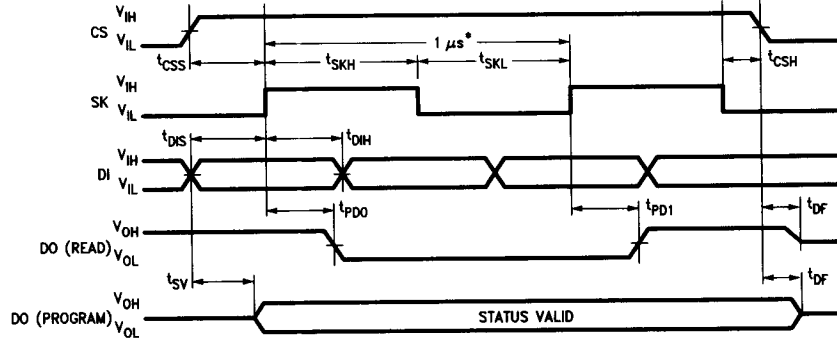

TL/D/8790-4

\*This is the minimum SK period (Note 2).

**Note 2:** The SK frequency specification for Commercial parts specifies a minimum SK clock period of  $1 \mu s$ , therefore in an SK clock cycle  $t_{SKH} + t_{SKL}$  must be greater than or equal to  $1 \mu s$ . For example if  $t_{SKL} = 250 ns$  then the minimum  $t_{SKH} = 750 ns$  in order to meet the SK frequency specification.

### READ:

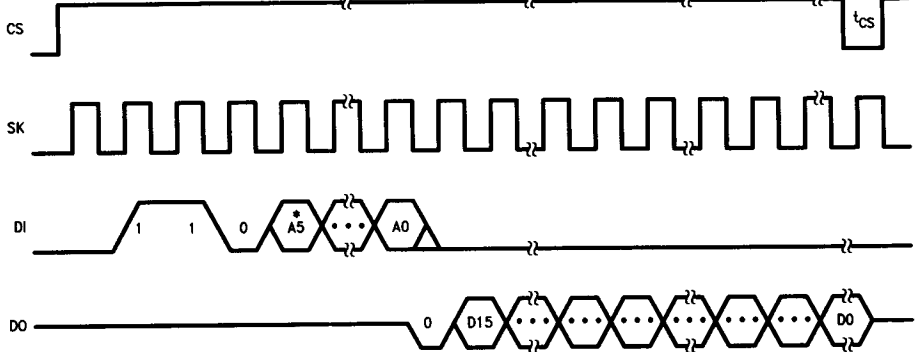

TL/D/8790-5

\*Address bit A5 becomes "don't care" for NMC93C26.

\*Address bits A5 and A4 become "don't care" for NMC93C06.

### WEN: DO = TRI-STATE

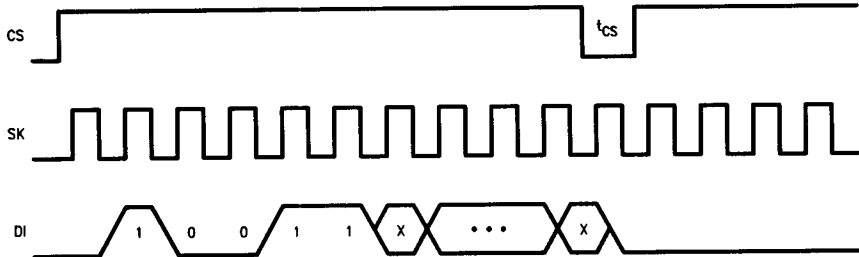

TL/D/8790-6

**Timing Diagrams** (Continued)

**EWDS:**  
DO := TRI-STATE

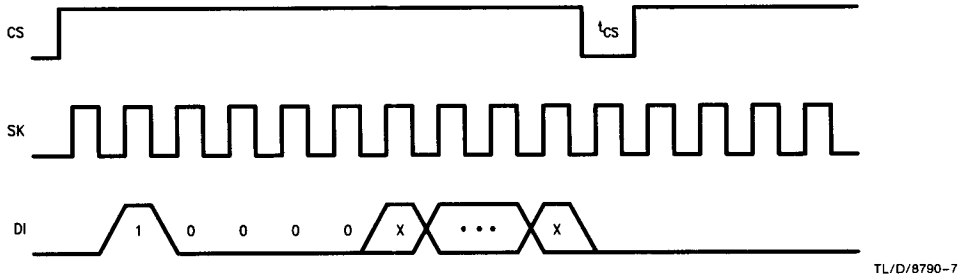

**WRITE:**

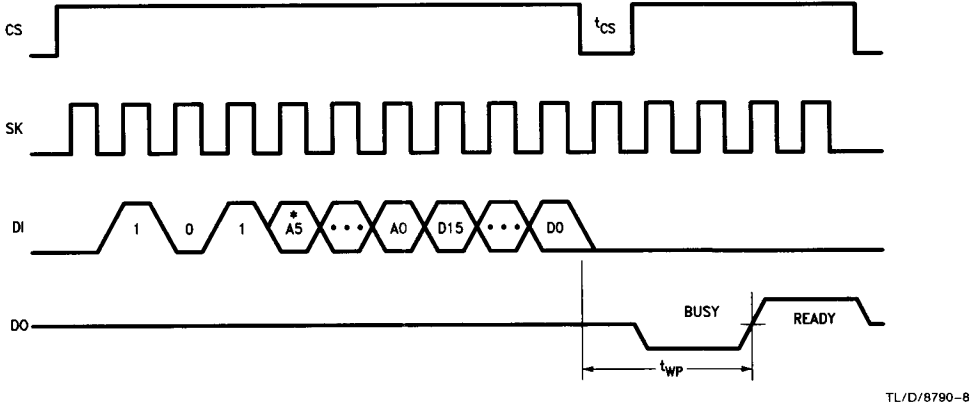

\*Address bit A5 becomes "don't care" for NMC93C26.  
\*Address bits A5 and A4 become "don't care" for NMC93C06.

**WRAL:**

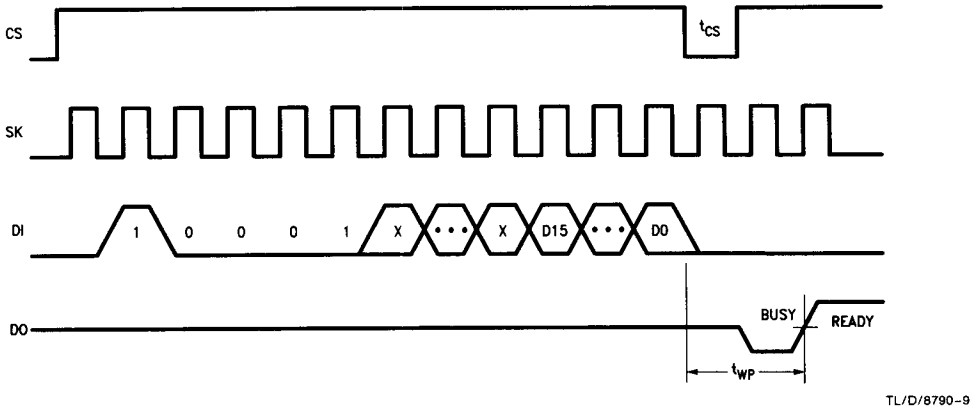

Timing Diagrams (Continued)

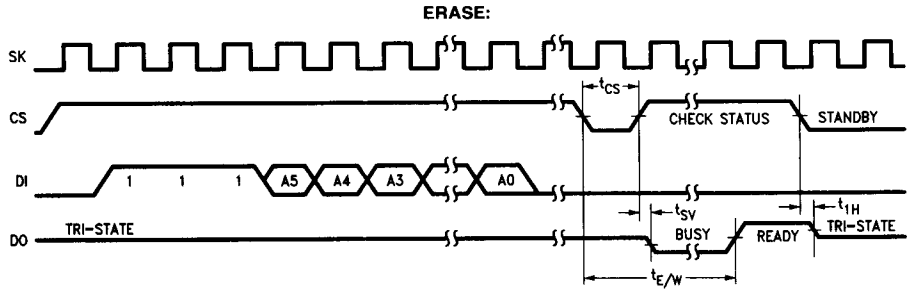

TL/D/8790-10

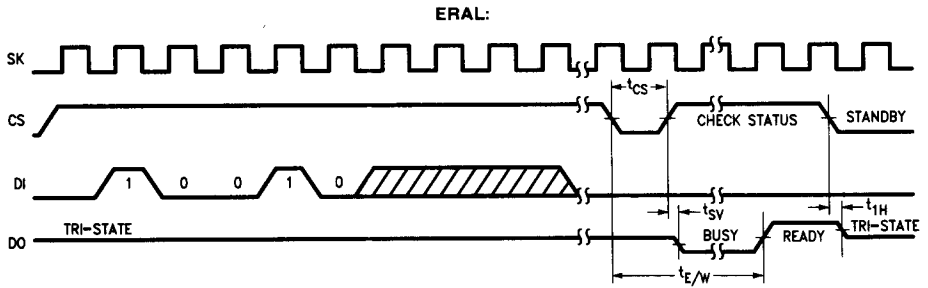

TL/D/8790-11